

# USER MANUAL

## DM0412P Low speed Centrifuge

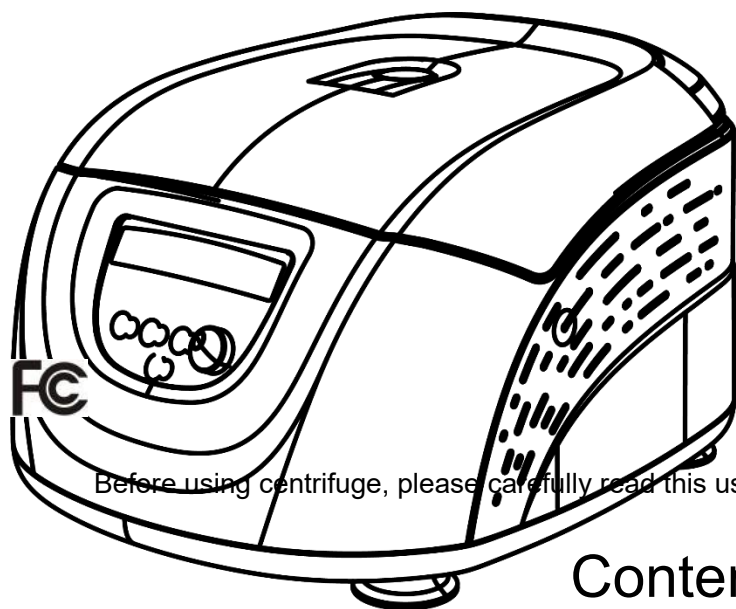

12301628 **CE**  
Ver.20221122

Before using centrifuge, please carefully read this user manual for efficient operation and safety.

### Contents

SAFETY REMINDER.....	3
1. INTENDED USE.....	6
2. SPECIFICATIONS.....	6
3. DECLARATION OF CONFORMITY.....	7
4. REQUIRED OPERATIONAL CONDITIONS.....	8
4.1 BASIC OPERATIONAL CONDITIONS.....	8
4.2 TRANSPORT AND STORAGE CONDITIONS .....	8
5. INSTALLATION.....	8
5.1 LOCATION.....	8
5.2 CONNECTION OF THE POWER CORD AND GROUNDING.....	9
6. STRUCTURE.....	9

---

---

<b>7. OPERATION PANEL.....</b>	<b>9</b>
<b>8. ROTOR PREPARATION.....</b>	<b>11</b>
8.1 PREPARE THE SAMPLES .....	11
8.2 INJECT THE SAMPLES INTO TUBES .....	11
8.3 KEEP THE TUBES BALANCED.....	11
8.4 INSPECT THE ROTOR.....	11
8.5 SYMMETRICALLY LOAD CENTRIFUGE TUBES INTO ROTOR .....	11
<b>9. OPERATION.....</b>	<b>12</b>
9.1 NORMAL OPERATION.....	12
<b>10. MAINTENANCE.....</b>	<b>15</b>
10.1 CLEANING.....	15
10.2 ROTOR INSTALLATION.....	16
<b>11. TROUBLESHOOTING.....</b>	<b>17</b>
11.1 POSSIBLE PROBLEMS AND SOLUTIONS.....	17
11.2 HOW TO OPEN THE DOOR .....	18
<b>12. INSTRUCTIONS FOR THE ROTOR AND TUBES.....</b>	<b>19</b>
12.1 ROTOR INSTRUCTIONS.....	19
12.2 TUBES.....	20
<b>13. CALCULATE RCF.....</b>	<b>22</b>
<b>14. RETURNING AND DISPOSAL.....</b>	<b>22</b>
14.1 RETURNING DEVICES.....	22
14.2 DISPOSAL.....	22
<b>15. WARRANTY.....</b>	<b>23</b>
15.1 WARRANTY OF CENTRIFUGE.....	23
15.2 WARRANTY OF THE ROTOR.....	23
<b>AFTER-SALES SERVICE.....</b>	<b>23</b>

---

## Safety Reminder

### Common safety precautions

Carefully read the following safety precautions for a thorough understanding.

- Follow the instructions and procedures described in this manual to operate this centrifuge safely.
- Carefully read all safety messages in this manual and the safety instructions on the instrument.
- Safety messages are labeled as indicated below. They are in combination with signal words of “WARNING” and “CAUTION” with the safety alert symbol to call your attention to items or operations that could be dangerous to you or other persons using this instrument. The definitions of signal words are as follows:

#### WARNING: Personal Danger

Warning notes indicate any condition or practice, which if not strictly observed, could result in personal injury or possible death.

#### CAUTION: Possible damage to instrument

Caution notes indicate any condition or practice, which if not strictly observed or remedied, could result in damage or destruction of the instrument.

NOTE: Notes indicate an area or subject of special merit, emphasizing either the product’s capability or common errors in operation or maintenance.

- Do not operate this centrifuge in any manner not described in this User manual. When in doubt or have any troubles with this centrifuge, ASK FOR

---

## HELP.

- The precautions described in this User manual are carefully developed in an attempt to cover all the possible risks. However, it is also important that you are alert for unexpected incidents. Be carefully operating this centrifuge.

## WARNING:

- This centrifuge is not explosion-proof. Never use explosive or flammable samples.
- Do not install the centrifuge in or near places where inflammable gases are generated or chemicals are stored.
- Do not place dangerous material within 30cm around the centrifuge.
- Make sure to prepare necessary safety measures before using samples that are toxic, radioactive or contaminated with pathogenic micro-organisms at your own responsibility.
- If the instrument, rotor and/or accessories that has been contaminated by solutions with toxic, radioactive or pathogenic materials, clean it according to the decontamination procedure that you are specified.
- If you require services at site, please sterilize and decontaminate it in advance, and then notice the service center involved in the details of the particular materials.
- Do not handle the power cord or turn on or off the POWER switch with wet hands to void electrical shocks.
- For safety purposes, do not enter within 30cm around this centrifuge while it is in operation.
- While the rotor is rotating, never forcedly release the door lock.

- 
- Unauthorized repairs, disassembly, and other services to the centrifuge except by our service center are strictly prohibited.

#### CAUTION

- This centrifuge must be located on one firm and level table.
- Make sure the centrifuge is horizontal before running.
- Make sure the angle between the door and cover is greater than 70 degrees when open the door.
- Be careful not put your fingers or hands between the door and cover when the door off.
- Do not move or relocate this centrifuge while it is running.
- If fluid spills in the rotor chamber, please promptly clean and dry with a dry cloth to avoid sample contamination.
- Ensure to remove any objects and fragments of the tubes dropped inside the rotor chamber before running this centrifuge.
- Cautions on rotors
  - (1) Always check for corrosion and damages on the rotor surface before using it. Do not use the rotor if an abnormality is found.
  - (2) Do not set the centrifuge speed beyond the allowable minimum speed of the rotor kits (rotor or adapters). Make sure to run it below the allowable minimum speed.
  - (3) Do not exceed the allowable imbalance.
  - (4) Use the rotor and tubes within their actual capacities.
  - (5) If the rotor is attached with a lid, ensure it is tightened before operation.

- If any abnormal condition occurs during operation, please stop it immediately and contact our service center. Notify the service center is a warning code if displayed.
- Vibrations are likely to damage the centrifuge, contact our service center if abnormality observed.

## 1. Intended use

This device is a medical product (laboratory centrifuge) within the context of the IVD Directive 98/79/EC. The centrifuge is used for the centrifugal separation of human blood or urine samples in the rotor in accordance with EN ISO 12772. Operator should be trained before using the centrifuge. Detailed operation, please refer to the User Manual below.

## 2. Specifications

Maximum speed	4500rpm(300-4500rpm), increment: 10rpm
Maximum RCF	2490×g, increment: 10×g
Maximum capacity	10ml×12, 15ml×8
Timer	30seconds -99minutes-HOLD, continuous operation
Noise	≤56dB(A)
Driving Motor	Brushless DC motor
Safety devices	Door interlock, Over-speed detector, Error code runtime display
Power requirements	Single-phase, 110V-240V, 50Hz/60Hz, 3A.
Ambient condition -Set-up site -Altitude -Ambient temperature -Humidity -Excess-voltage category -Pollution degree	Indoor only Up to 2000 m above sea level 2°C ~ 40°C 80% II

	2	
Device protection class	I	
EMC -Emitted interference, Interference immunity	EN/IEC 61326-1 Class A	FCC Class A
Dimensions (mm)	(L) 301× (W) 354× (H) 217	
Weight	6kg	
Additional features	Speed/RCF switch, Pulse operation, LCD display of runtime status, buzzer notification & alert	

### 3. Declaration of Conformity

Construction in accordance with the following safety standards:		
EN 61010-1		
EN 61010-2-020		
EN 61010-2-101		
Construction in accordance with the following EMC standards:		
EN 61326-1/ FCC Part 15 Subpart B/ IECS 001		
EN 61326-2-6:2006		
Associated EU guidelines:		
EMC directive: 2014/30/EU		
LVD	directive:	2014/35/EU
IVD directive: 98/79/EC		
This ISM device complies with Canadian ICES-001.		
Cet appareil ISM est conforme à la norme NMB-001 du Canada.		

Changes or modifications not expressly approved by the party responsible for compliance could void the user's authority to operate the equipment.

NOTE: This equipment has been tested and found to comply with the limits for a Class A digital device, pursuant to Part 15 of the FCC Rules. These limits are designed to provide reasonable protection against harmful interference when the equipment is operated in a commercial environment. This equipment generates, uses, and can radiate radio frequency energy and, if not installed and used in

---

accordance with the instruction manual, may cause harmful interference to radio communications. Operation of this equipment in a residential area is likely to cause harmful interference in which case the user will be required to correct the interference at his own expense.

## **4. Required Operational Conditions**

### **4.1 Basic operational conditions**

- (1) Power: 110V-240V, 50Hz/60Hz, 3A.
- (2) Ambient temperature: 2°C~40°C.
- (3) Relative humidity: ≤80%.
- (4) No vibration and airflow around.
- (5) No electric dust, explosive and corrosive gases around.

### **4.2 Transport and storage conditions**

- (1) Storage temperature: -40°C~55°C.
- (2) Relative humidity: ≤93%.

## **5. Installation**

This section describes the instructions that you should abide when install the centrifuge to ensure your safety and the optimum performance. Before moving the centrifuge, the rotor must be removed.

### **WARNING**

- Improper power supply may damage centrifuge.
- Make sure the power source conforms to the required power supply before connecting.

### **5.1 Location**

- (1) Place this centrifuge on a firm、flat and level surface, ensure the four feet of this centrifuge stand on the counter firmly. Avoid installing on a slippery surface or surface prone to vibration.
- (2) Ideal ambient temperature is 20°C±5°C, avoid placing the centrifuge in direct sunlight if temperature exceeds 30°C.
- (3) Keep clear of the centrifuge at least 10cm on both sides and at least 30cm behind it to guarantee the cooling efficiency.

---

( 4 ) Keep away from heat or water to avoid sample temperature issues or centrifuge failures.

## **5.2 Connection of the power cord and grounding**

### **WARNING**

- To avoid electrical shocks, ensure your hands are dry when touching the power cord.
- This centrifuge must be grounded properly.

An minimum 10A outlet providing a sufficient ground is required, and this must meet local safety requirements.

## **6. Structure**

Figure 6-1 Front view of the centrifuge

Figure 6-2 Rear view of the centrifuge

## **7. Operation panel**

Figure 7-1 Operation panel





Item	Symbol	Name	Function
1		Program button	Press the button to choose the programs
2		Step button	Press for step choose and hold on 5s for RCF switch display
3		Open/ lock button	Press the button to open the door The button is not available when the centrifuge is running.
4		Start/ Stop button	Press the button to start running. The centrifuge will brake to stop running if pressed during centrifugation.
5		Parameter button	Clockwise rotate to increase program values. Rotate anti-clockwise to decrease parameter values. Press the button, shift between speed and RCF display.



Figure 7-2 The interface

Main interface

is as figure 7-2. The program is for PRP function. The speed is set to be 3480rpm, the door lock is released and the running time is 3 minutes. When speed symbol is rotating, this indicates the centrifuge is running. If the rotation is faster, the speed is higher. Time symbol displays the time setting.

---

## **8. Rotor Preparation**

### **8.1 Prepare the samples**

### **8.2 Inject the samples into tubes**

#### **CAUTION**

- Do not overload samples into the centrifuge which will cause leaking.
- Do not exceed the actual capacity allowed in the user manual.

### **8.3 Keep the tubes balanced**

- Although the centrifuge can accept sample balancing by eye, we recommend that you keep this centrifuge in a well-balanced condition to extend its life expectancy.
- Never intentionally run the centrifuge under an unbalanced condition even though the allowable imbalance is not exceeded.

### **8.4 Inspect the rotor**

Check the rotor for corrosion or scratches before using.

#### **CAUTION**

- If any abnormality such as corrosion or scratches are found, stop using the rotor and contact our service center.
- Only manufacturer's rotors must be used with the unit.

### **8.5 Symmetrically load centrifuge tubes into rotor**

#### **CAUTION**

- Make sure the rotor lid is securely fixed on the rotor, as well as the rotor and shaft are tightened. Otherwise, the rotor may be moved off while rotating and cause damage to the centrifuge and rotor.
- Firmly tighten the rotor lid to the rotor.

---

## 9. Operation

### CAUTION



- Do not push or lean against the centrifuge while it is running.
- Do not run the centrifuge when fragments or sample solutions are left in the centrifuge chamber. Always keep the centrifugal chamber clean.
- If the centrifuge makes strange noise during operation, stop it immediately and contact our service center. Notify them of the warning code if displayed.

### 9.1 Normal operation

Turn on the power switch, centrifuge will display the running interface last time after passing the self-diagnostic checks.

#### 9.1.1 Preloaded Programs Operation

##### 1) PRP Program

(1) Press the  button to select PRP program. Press button  to start running.

- The door must be locked before rotor starts spinning.
- Timer will operate once the speed setting value is reached, the screen displays the remaining run time.

(2) View and modify the operation programs



- Press parameter knob  for 5 seconds, When flashing, rotate parameter knob to modify values. Release the button after 5 seconds, and the centrifuge will save the new value.

(3) Warning display

- If an error occurs during the operation, the centrifuge will brake to stop automatically, and display the error code on the time/display area. The error code can be checked in the table 11-1, and corrective actions can be applied accordingly.



---

## 2) PRF Program

(1) Press the  button to select PRF program. Press button  to start running.

- The door must be locked before rotor starts spinning.
- Timer will operate once the speed setting value is reached, the screen displays the remaining run time.

(2) View and modify the operation programs

- Press parameter knob  for 5 seconds, When flashing, rotate parameter knob  to modify values. Release the button after 5 seconds, and the centrifuge will save the new value.

(3) Warning display



- If an error occurs during the operation, the centrifuge will brake to stop automatically, and display the error code on the time/display area. The error code can be checked in the table 11-1, and corrective actions can be applied accordingly.

## 3) CGF Program

(1) Press the  button to select CGF program. Press button  to start running.

- The door must be locked before rotor starts spinning.
- Timer will operate once the speed setting value is reached, the screen displays the remaining run time.

(2) View and modify the operation programs

- λ Press parameter knob  for 5 seconds, When flashing, rotate parameter knob  to modify values. Release the button after 5 seconds, and the centrifuge will save the new value.

(3) Warning display

- If an error occurs during the operation, the centrifuge will brake to stop automatically, and display the error code on the time/display area. The error code can be checked in the table 11-1, and corrective actions can be applied accordingly.

## 4) End the operation

(1) The centrifuge will brake when it reaches the set time or  button is

---

pressed.

λ When the rotor stops rotating, the centrifuge will start beeping to alert the operation has finished.

(2) Open the door



- The door can be released automatically when the operation has stopped.
- With the door closed, you are able to press the  button to open it.
- After ending the operation, the program will store the setting parameters of this operation, and will recall these parameters when restarting the program.

(3) Open the door and take out the rotor and samples.

## 9.1.2 Customized program operation

Press the  button to select P program. There are 9 programs (P1-P9) available and 6 steps for each program.

### 1) P1-P9 programs

(1) Press the  button to select P1 program. When P1 icon flash, press parameter knob  to confirm P1 program. Rotate the parameter knob to set the speed value and press to set time value. Press step button  to enter second step parameters setting. There are maximum 6 steps available for setting.

(2) Press button  to start running.

(3) Warning display

- If an error occurs during the operation, the centrifuge will brake to stop automatically, and display the error code on the time/display area. The error code can be checked in the table 11-1, and corrective actions can be applied accordingly.

### 2) End the operation

(1) The centrifuge will brake when it reaches the set time or  button is pressed.



- When the rotor stops rotating, the centrifuge will start beeping to alert the operation has finished.

(2) Open the door

- The door can be released automatically when the operation has stopped.

- 
- With the door closed, you are able to press the  button to open it.
  - After ending the operation, the program will store the setting parameters of this operation, and will recall these parameters when restarting the program.
- (3) Open the door and take out the rotor and samples.

## 9.2 RCF operation

- (1) Turn on the power switch
- (2) Set a RCF (Relative Centrifugal Force) value
- Press the step button  for 5 seconds and the speed symbol will flash into RCF value input status, press again for 5 seconds to return RPM value input mode.
  - Rotate program knob  to input a RCF value, RCF increment is 10×g.
- (3) Set operating conditions
- The other operation, please refer to the section 8.1.

## 9.3 Reset

If you need reset the programs parameters, press the door button  for 10 seconds;

# 10. Maintenance

## 10.1 Cleaning

### CAUTION

- If do not follow the recommended instructions for cleaning or disinfecting this may damage the centrifuge.

- (1) Centrifuge
- If the centrifuge is exposed to ultraviolet rays for a long time, the color of the door may be changed or the label may be peel off. After using, cover the centrifuge with a piece of cloth to protect it from direct exposure.
  - If the centrifuge needs cleaning, clean it with a cloth or sponge moistened with

---

a neutral detergent solution.

- Sterilize the centrifuge by wiping with a cloth moistened with 70% ethanol solution.

#### (2) Rotor chamber

##### CAUTION

- Do not directly pour water, neutral detergent or disinfectant solution into the rotor chamber, otherwise fluids may leak into the drive units and cause corrosion or deterioration to the bearings.

- If the rotor needs cleaning, clean with cloth or sponge moistened with a neutral detergent solution. Sterilize the centrifuge by wiping with a cloth moistened with 70% ethanol solution.

#### (3) Drive shaft

- We recommend regular maintenance for drive shaft. You can wipe the drive shaft with soft cloth, and then apply a thin coat of silicon grease.

#### (4) Door

- Clean and sterilize the door using the same method as the section (1) above.

#### (5) Rotor

- To prevent corrosion, remove the rotor from rotor chamber. If not in use for a long term, then detach the rotor lid and turn upside down to dry the tube holes and keep clean.
- For sample leaks in the rotor, rinse the rotor with water. Apply a thin coat of silicon grease to the rotor when it is completely dry.
- The rotor should be checked every 3 months to ensure the tube and rotor holes keep are clean and apply a thin coat of silicon grease.

## 10.2 Rotor Installation

### (1) Installation

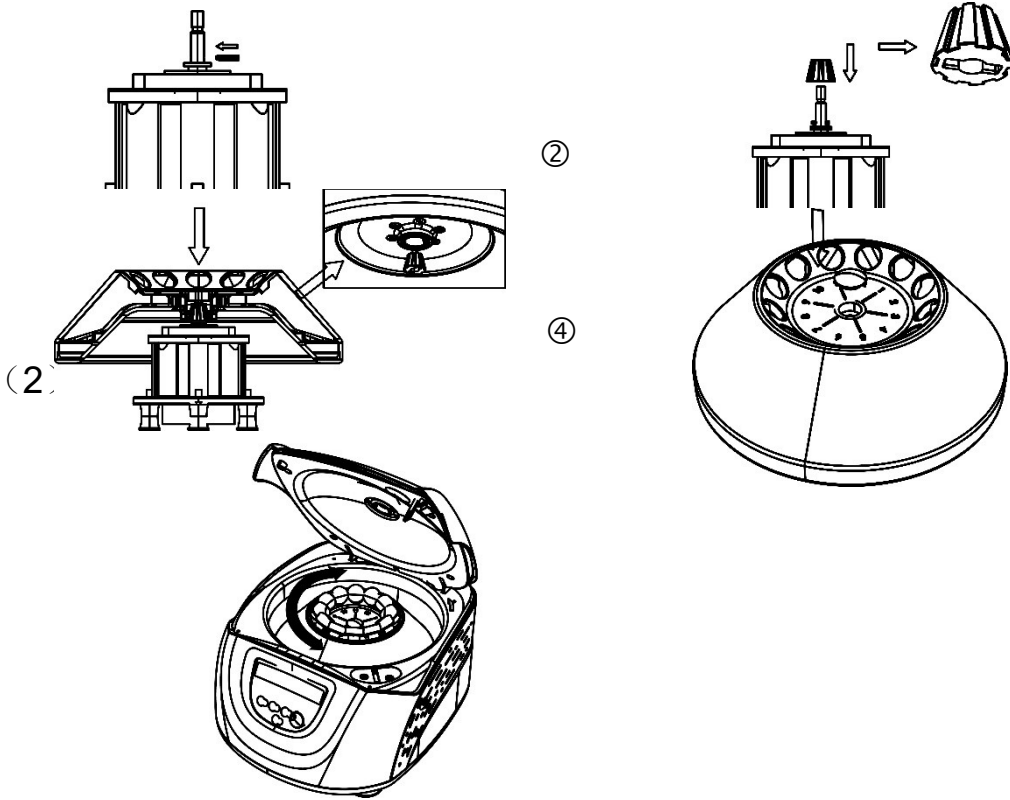

## 11. Troubleshooting

### 11.1 Possible problems and solutions

This centrifuge has a self-diagnostic function. If a problem occurs, an error/warning code will be displayed on the time display screen, and the operator can determine the malfunction with the alarm code below.

Symptom	Causes	Solutions
Nothing appears on the screen when the POWER is turned on.	·Building power circuit breaker trips.	·Remove the trouble and turn on the POWER.
Abnormal vibration	·Rotor do not match with spindle ·Samples are imbalance	·Install again the rotor ·Weighting scales, install symmetrically

Alarm code appeared on the time display screen	E-02 Door fault	<ul style="list-style-type: none"> <li>·The door opened in running.</li> <li>·The  button is pressed while the door opening.</li> </ul>	<ul style="list-style-type: none"> <li>·Close the door immediately.</li> <li>·Close the door , and then start to operate.</li> </ul>
	E-06 Set wrong speed	<ul style="list-style-type: none"> <li>·The setting speed exceed the allowable range.</li> </ul>	<ul style="list-style-type: none"> <li>·Modify the speed value.</li> </ul>
	E-10~86	<ul style="list-style-type: none"> <li>·Read the service manual</li> </ul>	<ul style="list-style-type: none"> <li>·Contact with service center</li> </ul>

Table 11-1 Possible problems and solutions

- Alarm codes E-1 ~ E-9 are related to incorrect operation/programming. You can continue running the centrifuge after implementing corrective procedures.

## 11.2 How to open the door

### 1) In the case of power on

#### CAUTION

- The door just can be opened while the power is on and rotor stops rotating.

(1) Turn on the power switch, release the door automatically.

(2) The door will be released automatically once the operation is finished.

(3) It is available to release the door by press  button once the rotor stops.

### 2) In the case of power outage

The door cannot be opened automatically if there is a power outage. It is available to be opened manually as follows.

(1) Ensure if the rotor has stopped rotating.

- Listen carefully to ensure no rotating sound can be heard.

(2) Insert a screw driver into a hole to open door.

- Holes are located on the left and right sides of the unit.

- Insert a screw driver into the two holes and push forward to release the door.

## 12. Instructions for the rotor and tubes

### CAUTION

- Read the instructions thoroughly, to properly load and use rotor.
- Do not exceed the allowable maximum speed of rotor, tube and adapters etc. Ensure the allowable maximum speed of adapters is lower than the rotor's maximum speed.

### 12.1 Rotor instructions

#### 1) Rotor structure

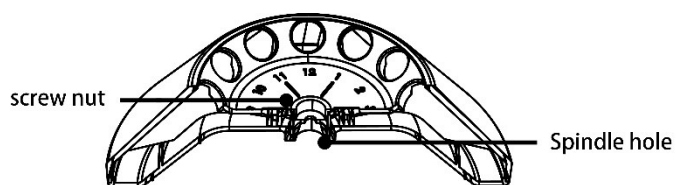
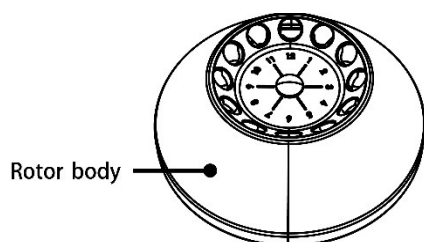

#### 1) Available rotors and adapt

Rotor type	Tubes	Tube s Per Rotor	Dimension (Φ×L mm)	Adapter s	Maximum speed (rpm)	Radiu s cm	Maximum RCF (×g)
A12-10P	15ml con	8	17×120		4500	11	2490
	1.5-5ml vacu	12	13×82	A10P15 mat	4500	9.8	2218
	4-7 ml vacu	12	13×106	A10P15	4500	11	2490
			16×75	A10P15 Mat		9.8	2218
8.5-10 ml vacu	12	16×107	A10P15	4500	11	2490	

	2.7-3 (EU) ml collection tube	12	11×66	A10P15 mat	4500	9.8	2218
	7.5-8.2 (EU)ml collection tube	12	15×92	A10P15	4500	11	2490

Table 12-1 Rotors and adapters

2) Notice

- The centrifuge rotor can separate samples with a density lower than 2.0g/ml. If the samples density is over 2.0g/ml, please calculate allowable speed depending on the following formula.

3) Autoclaving

A12-10P rotor is made of plastic, cannot be high-pressure sterilization and UV irradiation, only ordinary sterilization can be used.

**12.2 Tubes**

1) Cleaning and sterilizing tubes

O: Applicable X: Inapplicable

Conditions		Materials	PA	PC	PP
Clea ning	Cleaning fluids	Acidic (pH5 or lower)	X	X	X
		Acidic (higher than pH5 )	O	O	O
		Alkaline (higher than pH9 )	O	X	O
		Alkaline (pH9 or lower)	O	O	O
		Neutral (pH7)	O	O	O

		Warm water(up to 70℃)	O	O	O
	Ultrasonic cleaning	Neutral detergent (pH7)	O	O	O
Sterilization	Autoclaving	115℃ (0.7kg/cm <sup>2</sup> ) 30minutes	O	O	O
		121℃ (1.0kg/cm <sup>2</sup> ) 20 minutes	X	O	O
		126℃ (1.4kg/cm <sup>2</sup> ) 15 minutes	X	X	X
	Boiling	15 to 30 minutes	O	O	O
	Ultraviolet sterilization	200-300nm	X	X	X
	Gas sterilization	Ethylene oxide	O	X	O
Formaldehyde		O	O	O	

PA: Polyallomer PC: Polycarbonate PP: Polypropylene

Table 12-2 Cleaning and sterilizing conditions for tubes

1) Cleaning PC tubes

PC material is low in chemical resistance against alkaline solutions. Avoid using neutral detergents with pH higher than 9. Note that pH of some neutral detergents are still higher than 9 even if diluted according to the manufacturer's instructions. Use detergent with its pH between 7 and 9.

2) Autoclaving PA、PC and PP tubes

PA begins softening at about 120℃, PC and PP at about 130℃. Autoclave PA tubes at 115℃ (0.7kg/cm<sup>2</sup>) for 30 minutes, PC and PP tubes at 121℃ (0.1kg/cm<sup>2</sup>) for 20 minutes. If a certain temperature is exceeded, the tubes may be deformed.

When use a sterilizing chamber, please operate as follows:

(1) Place tubes in vertical position, mouths upward. If tubes are placed sideways, they may deform into an oval shape due to gravity.

(2) Remove locking nut and lid to prevent from deformation or rupture.

(3) Wait until the sterilizing chamber cools down to the room temperature before removing tubes.

4) Conditions and life expectancy of tubes

The life expectancy of plastic tubes depends on the characteristics of samples, speed of the rotor used, temperature applied and so on. When the plastic tubes

---

are used for ordinary aqueous samples (pH between 5.0 and 9.0), their life expectancies are defined as follows.

Be operated at the maximum speed:

High quality tubes (PA、PC、PP): 30-50 operations

Ordinary tubes(PA、PC、PP): around 10 operations (Using in low speed can extend the tube life) .

Life expectancy of tubes also depends on the pretreatment conditions such as cleaning and sterilization, lifetime can be cut down.

Notice: Do not use damaged or cracked tubes.

### **13. Calculate RCF**

An RCF can be determined with the following calculation formula.

$$RCF=1.118 \times r \times n^2 \times 10^{-5}$$

r—rotating radius, unit: cm; n—rotating speed, unit: rpm

## **14. Returning and Disposal**

### **14.1 Returning Devices**

Before returning the device, a transport securing device has to be installed.

If the device or its accessories are returned back, in order to provide protection for people, the environment and materials, it has to be decontaminated and cleaned before being shipped.

### **14.2 Disposal**

Before disposal, the device must be decontaminated and cleaned to protect people, the environment and property. When you are disposing of the device, the respective statutory rules must be observed.

Pursuant to guideline 2002/96/EC (WEEE), all devices supplied after August 13,2005 may not be disposed as part of domestic waste. The device belongs to group 8 (medical devices) and is categorized in the business-to-business field.

The icon of the crossed-out trash can shows that the device may not be disposed as part of domestic waste. The device belongs to group 8 (medical devices) and is categorized in the business-to-business field.

The waste disposal guidelines of the individual EC countries might vary. If necessary, contact your supplier.

---

## **15. Warranty**

### **15.1 Warranty of centrifuge**

This centrifuge is guaranteed for one years from the date of delivery provided that it has been operated and maintained properly.

### **15.2 Warranty of the rotor**

The rotor is guaranteed for 5 years from the date of delivery upon manufacturer. Please pay attention, do not use the rotor once it has been corrosion or fatigue damage. The warranties of the centrifuge and the rotor become invalid in the case of the following conditions even if within the guarantee period expires:

- (1) Failures caused by incorrect installation.
- (2) Failures caused by rough or improper handling.
- (3) Failures caused by conveyance or relocation after installation.
- (4) Failures caused by unauthorized disassembly or modification.
- (5) Failures caused by using non-standard spare parts or accessories and unauthorized modification of the rotor or centrifuge.
- (6) Failures caused by natural disasters including fire, earthquakes and so on.
- (7) Consumables and parts have a limited guarantee period.

## **After-sales service**

In order to ensure to operate centrifuge safely and efficiently, it is necessary for regular maintenance. If centrifuge has problems, do not attempt to repair it by yourself. Contact our sales or service center.

CONTACT US



DLAB Scientific Co., Ltd  
Yu An Road 31, Beijing Airport Economic core zone,  
Shun yi District, Beijing, China 101318  
Tel: 86-10- 85653451/52/53  
Fax: 86-10-85653383  
E- mail: [info@dlabsci.com](mailto:info@dlabsci.com)  
web: [www.dlabsci.com](http://www.dlabsci.com)