

# Tube Roller user manual

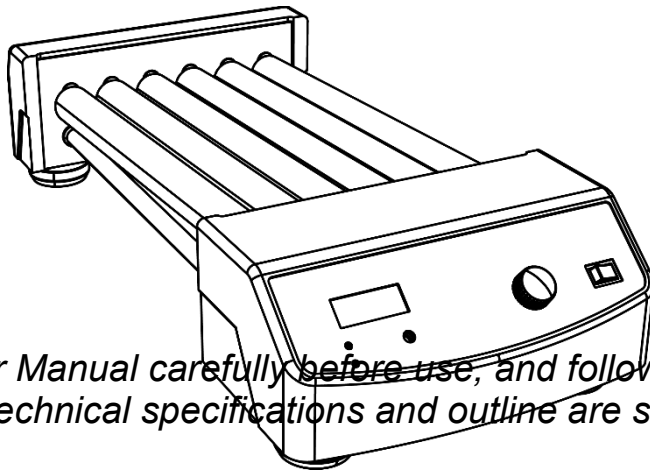

*Please read the User Manual carefully before use, and follow all operating and safety instructions! Technical specifications and outline are subject to change without prior notice.*

**C EFC**  12302090  
Ver.20220118

## CONTENTS

3.1. RECEIVING INSPECTION.....	5
3.2. LISTING OF ITEMS.....	5
4.1 CONTROL.....	6
4.2 DISPLAY.....	8

---

## **Preface**

Welcome to the “Tube Roller User Manual”. Users should read this manual carefully, follow the instructions and procedures, and beware of all the cautions when using this instrument.

## **Service**

When help needed, you can always contact the service department of manufacturer for technical support in the following ways:

Please provide the customer care representative with the following information :



- Serial number (on the rear panel)
- Certification
- Description of problem (i.e., hardware or software)
- Methods and procedures adopted to resolve the problems
- Your contact information

## **Warranty**

This instrument is warranted to be free from defects in materials and workmanship under normal use and service, for a period of 24 months from the date of invoice. The warranty is extended only to the original purchaser. It shall not apply to any product or parts which have been damaged on account of improper installation, improper connections, misuse, accident or abnormal conditions of operation.

For claims under the warranty please contact your local supplier. You may also send the instrument directly to manufacturer, enclosing the invoice copy and by giving reasons for the claim.

## 1. Safety Instructions

	<p><b>Warning!</b></p> <ul style="list-style-type: none"><li>● Read the operating instructions carefully before use.</li><li>● Ensure that only trained staff works with the instrument.</li></ul>
	<p><b>Protective ground contact !</b></p> <ul style="list-style-type: none"><li>● Ensure the socket must be grounded (protective ground contact) before use.</li></ul>

- When working wear personal safety guards to avoid the risk of:
  - Splashing liquids
  - Broken glass containers
- Follow the safety instructions, guidelines and accident prevention regulations.
- Do not touch the running parts, moving instrument care not rolling your fingers.
- Set up the instrument in a spacious area on a stable, clean, non-slip, dry and fireproof surface. Do not operate the instrument in explosive atmospheres, with hazardous substances or under water.
- If the instrument does not run smoothly, please decrease the motor speed.
- Firmly secure the accessories and vessels in place to avoid damage or risk.
- Preparation of samples may lead to dangerous flammable. Only process samples that will not react dangerous.
- Use the standard accessories listed in the “accessories” section, and follow the instructions to use accessories to ensure safety. Please switch off the power before assembly of accessories, confirm the instrument and accessories are intact before switch on each time.
- The instrument only be opened by expert, please switch off before use.
- The voltage stated on the nameplate must correspond to the mains voltage.
- Do not cover the instrument during running. Prevent the collision and extrusion to instrument and accessories.
- Keep away from high magnetic field.

---

## **2. Proper use**

The instrument is designed for mixing sticky substance in schools, laboratories or factories. It can be installed on a variety of impeller, for different viscosity of the medium. This instrument is not suitable for using in residential areas or other constraints mentioned in Chapter 1.

Do not use the accessories recommended by the manufacturer, or failure to use the instructions, may be caused unsafe situation.

---

### 3. Inspection

#### 3.1. Receiving Inspection

Unpack the instrument carefully and check for any damages which may have arisen during transport. If it happens, please contact manufacturer/supplier for technical support.

**Note:**

If there is any apparent damage to the system, please do not connect to the power line.

#### 3.2. Listing of Items

Items	Qty
Main unit	1
Power cable	1
User Manual	1

Table 1

## 4. Control and Display

### 4.1 Control

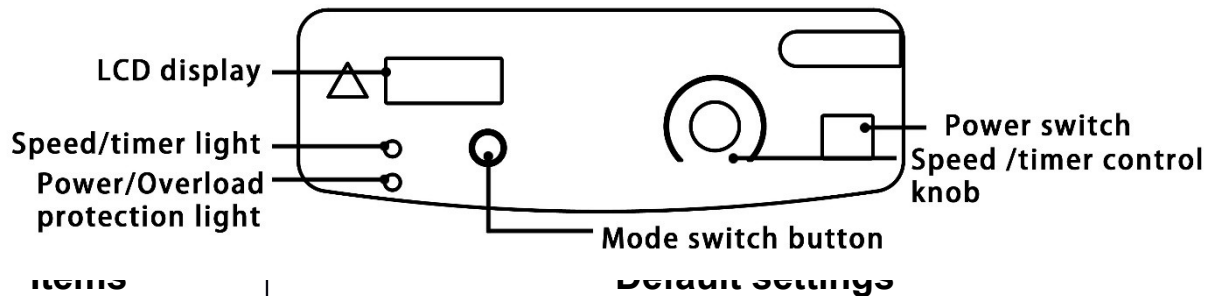
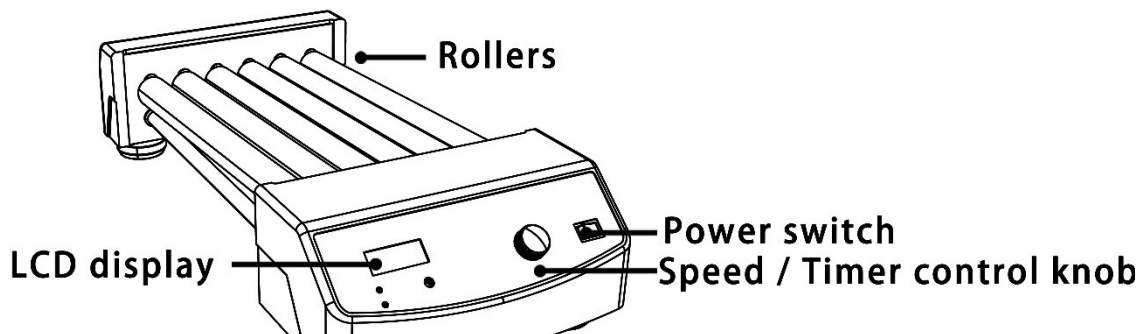

Items	Default settings
Mode switch button	Shift speed and time display.
Speed /timer control knob	Set speed and time by rotating speed/timer control knob. Push on/off to start/stop rotating function.
Speed/timer light	Green/Red LED display light. Different colors of LED light show the value for speed or time that LCD screen currently displays. Green LED light shows that LCD screen currently displays speed. Red LED light shows that LCD screen currently displays time.

Power/Overload protection light	Green/Red LED display light. LED light shows green when switch on, LED light shows red when starts overload protection. When the torque reaches limited value, overload protection function will be started. At the same time overload protection light flashes, while the system stops running.
LCD display	LCD displays the real working state and all setting values.
Power switch	Switch ON or OFF the instrument.

Table 2

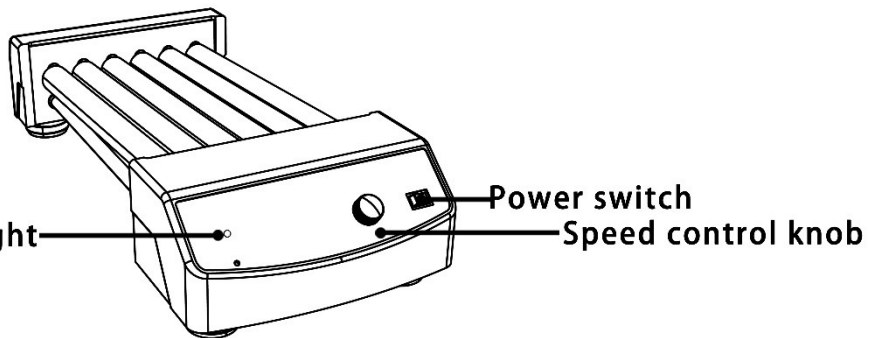

<b>Item</b>	
Speed control knob	Rotating speed control knob to start/stop rotating function.
Power light	Green LED display light.
	LED light shows green when switch on.
Power switch	Switch ON or OFF the instrument.

Table 3

## 4.2 Display

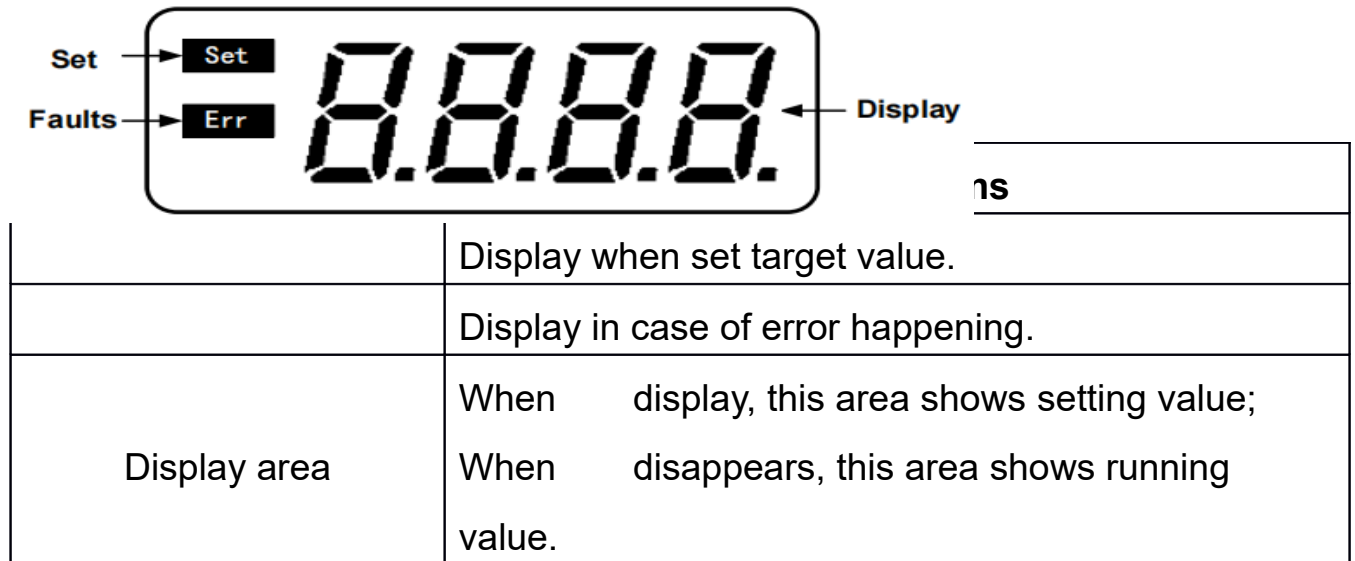

Table 4

## 5. Operation

- Place the Rotator in safe and stable surface, ensure the required operating voltage and power supply voltage matched, and the socket must be earthed reliably.
- Connect the power cable.
- Switch ON instrument.
- The instrument begins self-checking.
- When initialization is over, LCD displays the last running values of speed.
- Rotate the speed/timer control knob to set target speed.
  - a. Press the speed/timer control knob to start rotating function. Press the speed/timer control knob again to stop rotating function.
  - b. Press the mode switch button, LCD displays time, and then rotating the speed/timer control knob to set target time. Press the speed/timer control knob to start rotating function at the set time. During operation, motion can be stopped at any time by pressing the speed/timer control knob. If the knob is pressed again, motion will start again and the timer will restart countdown. When the timer reaches zero, the unit will be automatically halted and an alert will sound.

If these operations above are normal, the instrument is ready to operate. If not,

the instrument may be damaged during transportation, please contact technical support of manufacturer/supplier.



**Note:**

The set values can be altered at any time.

## 6. Faults

- Instrument cannot be powered ON when start rotating function.
  - Check whether the power cable is connected.
- Rotating function suddenly stop
  - Power/overload protection light changed to red, LCD displays “Er 03”, indicate the current failure is “overload protection”.
  - Pressing the speed/timer control knob first to close rotating function, and then restart rotating function after lowered load. If rotating function cannot start, then repeat the process and gradually reduce load.

## 7. Maintenance and cleaning

- Proper maintenance can keep instrument working properly and lengthen its lifetime.
- Do not spray cleanser into the instrument when cleaning.
- Do not remove the power line when cleaning. Only use recommended cleansers:

Dyes	isopropyl alcohol
Construction materials	water containing tenside/ isopropyl alcohol
Cosmetics	water containing tenside/ isopropyl alcohol
Foodstuffs	water containing tenside
Fuels	water containing tenside

- Before using other method for cleaning or decontamination, the user must ascertain with the manufacturer that this method will not damage the instrument. Wear the proper protective gloves during cleaning of the instrument.

**Note:**

- Electronic device cannot clean with cleanser.
- If you require maintenance service, must be cleaned the instrument in advance to avoid pollution of hazardous substances, and to send back into original packing.
- If the instrument will not use for a long time, please switch off and place in a dry, clean, room temperature and stable location.

## 8. Associated standards and regulations

Construction in accordance with the following safety standards:

EN 61010-1

UL 3101-1

CAN/CSA C22.2(1010-1)

EN 61010-2-10

Construction in accordance with the following EMC standards:

EN 61326-1

Changes or modifications not expressly approved by the party responsible for compliance could void the user's authority to operate the equipment.

**NOTE:** This equipment has been tested and found to comply with the limits for a Class A digital device, pursuant to Part 15 of the FCC Rules. These limits are designed to provide reasonable protection against harmful interference when the equipment is operated in a commercial environment. This equipment generates, uses, and can radiate radio frequency energy and, if not installed and used in accordance with the instruction manual, may cause harmful interference to radio communications. Operation of this equipment in a residential area is likely to cause harmful interference in which case the user will be required to correct the

---

interference at his own expense.

## 9. Specifications

Items	Specifications		
	MX-T6-Pro	MX-T6-S+	MX-T6-S
Voltage [VAC]	100-240		
Frequency [Hz]	50/60		
Power [W]	30	25	25
Number of rollers	6		
Roller size [length x diameter, mm]	280 × 30		
Motor type	DC brushless motor	DC brushless motor	Dc brush motor
Speed range [rpm]	10~70	0-70	
Speed display	LCD	-	
Timer range [min]	1~1199	-	
Timer display	LCD	-	
Run type	Timer/Continuous operation	Continuous operation	
Overall Dimensions [mm]	470×260×120		
Weight [kg]	5.1	4.5	
Permissible ambient temperature [°C]	5-40		
Permissible relative humidity	80%		
Protection class acc. to DIN EN 60529	IP21		

Table 5

---

## CONTACT US



### **DLAB Scientific Co., Ltd**

Yu An Road 31, Beijing Airport Economic core zone,  
Shun yi District, Beijing, China 101318

Tel: 86-10- 85653451/52/53

Fax: 86-10-85653383

E- mail: [info@dlabsci.com](mailto:info@dlabsci.com)

web: [www.dlabsci.com](http://www.dlabsci.com)